

The Ferrell-Ross Crumbler

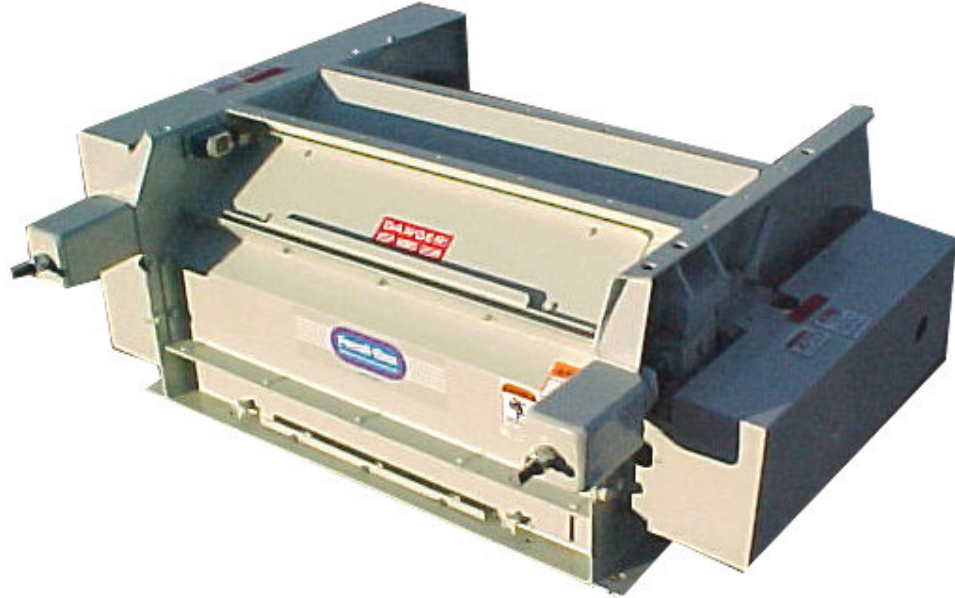

Available In:

- 8 x 37
- 8 x 55
- 12 x 72

Features:

- Chilled cast iron rolls
- Roll corrugations cut to customer specifications
- V Belt Drive
- Automatic cut off switches
- Built in by-pass
- Enclosed drive guard
- Tension spring roll protection

Ferrell-Ross Crumblers are designed to break pellets into smaller particles. Most Crumbler applications align the crumbler directly below a Pellet Cooler. The output from the crumbler can be routed to a separating screener for classification or to another processing component. Large screenings, or overs, can be returned to the crumbler for further reduction, while the fine material can be returned to the pellet mill for repelleting.



1440 SOUTH ADAMS STREET, BLUFFTON, IN 46714 USA (260) 824-3400 (800) 248-8318 FAX (260) 824-5463

www.atferrell.com

info@atferrell.com

The Ferrell-Ross Crumbler

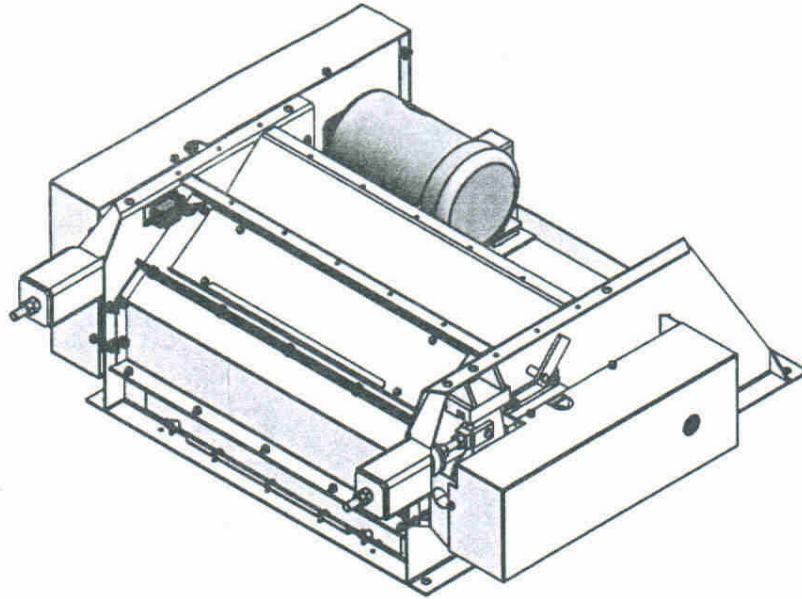

The Ferrell Ross pellet crumbler has chilled cast iron rolls. The rolls are driven by a V-Belt drive enclosed in OSHA style guards. The roll gap is designed to maintain integrity with the tension roll spring.

The Ferrell Ross pellet crumbler has many advantages:

- Bolt on bearings, which require no bearing alignment
- Robust bearing support
- Tension rolls spring system, handles roll separation forces
- Full access to rolls for inspection



1440 SOUTH ADAMS STREET, BLUFFTON, IN 46714 USA (260) 824-3400 (800) 248-8318 FAX (260) 824-5463
www.atferrell.com info@atferrell.com