

FERRELL-ROSS STEAM CHEST



Ferrell-Ross Steam Chests are robustly constructed of 10 gauge 304 Stainless Steel. Our sharply sloped cone section ensures Mass Flow and provides first-in-first-out cooking with no rat holing, bridging, or other flow problems. Our steam chest uses exclusive rolled ring steam injection design which produces an excellent cook.

Ferrell-Ross steam chests in larger diameters offer dual ring steam injection to enhance cooking. Rather than using a sparge or one ring to handle 66" and larger diameters, we split the diameter twice and put a steam ring within a steam ring, all concentric with the tank walls and doubling the effective cooking area.

Ferrell-Ross offers a wide range of Steam Chests varying in capacity from 148 cu/ft per hour up to 1120 cu/ft per hour. Typical retention times vary from 30-70 minutes depending on product type.

Ferrell-Ross

MATERIALS PROCESSING & RECOVERY

1440 SOUTH ADAMS STREET, BLUFFTON, IN 46714 USA (260) 824-3400 (800) 248-8318 FAX (260) 824-5463
www.ferrell-ross.com info@atferrell.com

STANDARD INSTALL STYLE DRAWING

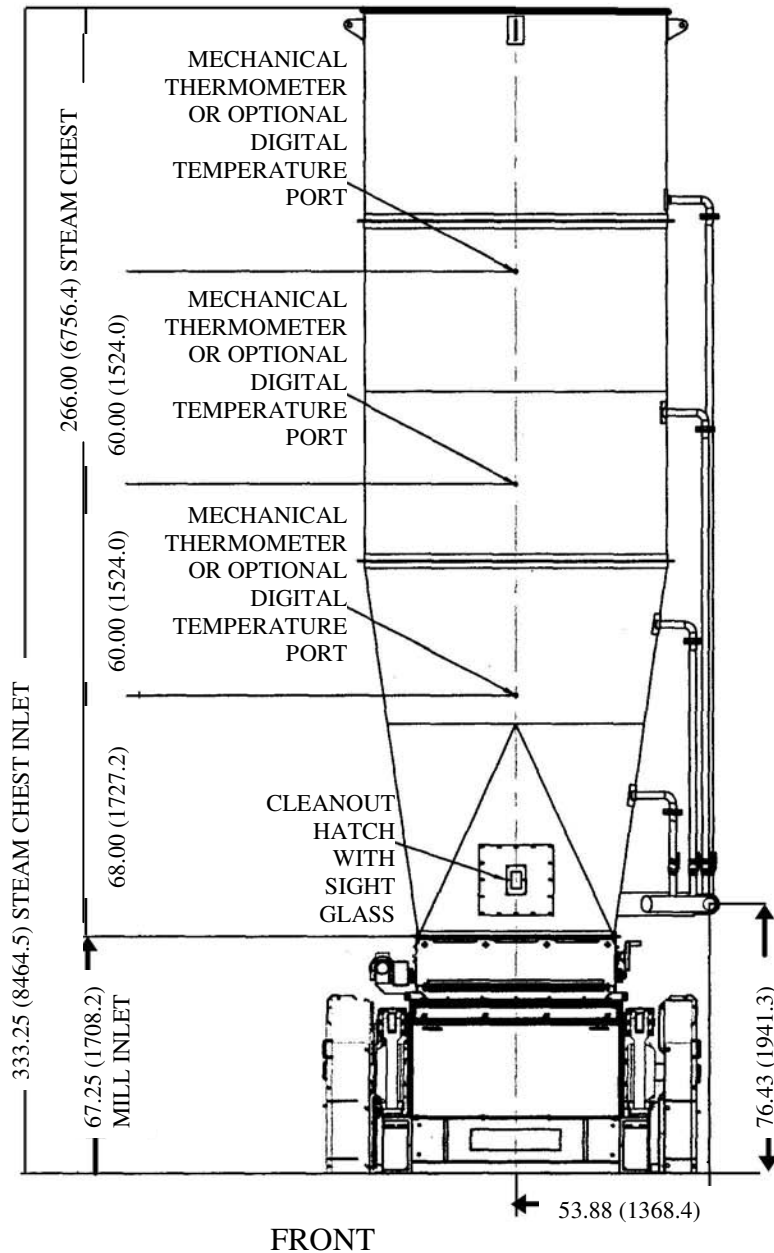

STANDARD FEATURES INCLUDE

- 10 Gauge Type 304 S/S Transition
- 10 Gauge S/S Housing
- 304 S/S Internal Piping and Gussets
- 1 Manway Access
- 1 Sight Glass
- Easy Reach Controls
- Temperature Gauges
- 1 Grain Inlet
- 1 Vent

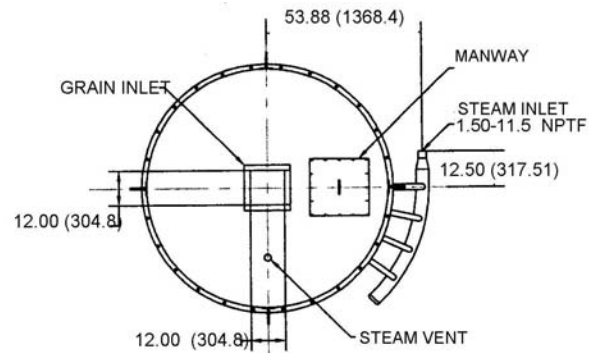

STANDARD DIAMETERS INCLUDE

- | | |
|-----|-----|
| 38" | 66" |
| 48" | 84" |

Ferrell-Ross
MATERIALS PROCESSING & RECOVERY

1440 SOUTH ADAMS STREET, BLUFFTON, IN 46714 USA (260) 824-3400 (800) 248-8318 FAX (260) 824-5463

www.ferrell-ross.com

info@atferrell.com