

Ferrell-Ross 24 X 48 Flake Master



Whether being used to process oil seed or animal feed, the 24x48 Flake Master is built to perform the task. If flaking soybeans for oil seed production, the 24 x 48 will process 200 TPD. For flaking corn to a 26lb flake for animal feed, the Dual Drive 24 x 48 will process 18 TPH. This is accomplished with the synchronized HTD dual drive.

Optional Features:

- Epoxy Paint
- Vibratory Feeder
- Manual Control Panel
- Touch Screen Control Panel
- Pneumatic Scrapers

With a base constructed of 16" ship channel, the 24 x 48 is designed to last through years of operation. Standard saddles are available in aluminum, nylon or stainless steel. The 5-15/16" journals come standard with double row spherical bearings incased in custom Ferrell-Ross Cast Iron Bearing Housings.

Other Standard Features:

- Single or Dual Drive Packages
- Stainless Steel Roll Covers & Center Section
- Heavy Duty Springs with Hydraulic Accumulator Protection
- Stainless Steel Pin Feeder with Slide Gate
- Variable Speed Feeder Control with Gearbox
- Convenient Roll Gap Adjustment
- Roll Preheat System
- Roll Removal from Front or Back
- Hydraulic Pump with Control

Ferrell-Ross

MATERIALS PROCESSING & RECOVERY

1440 SOUTH ADAMS STREET, BLUFFTON, IN 46714 USA (260)824-3400 (800) 248-8318 FAX (260) 824-5463
www.ferrell-ross.com info@atferrell.com

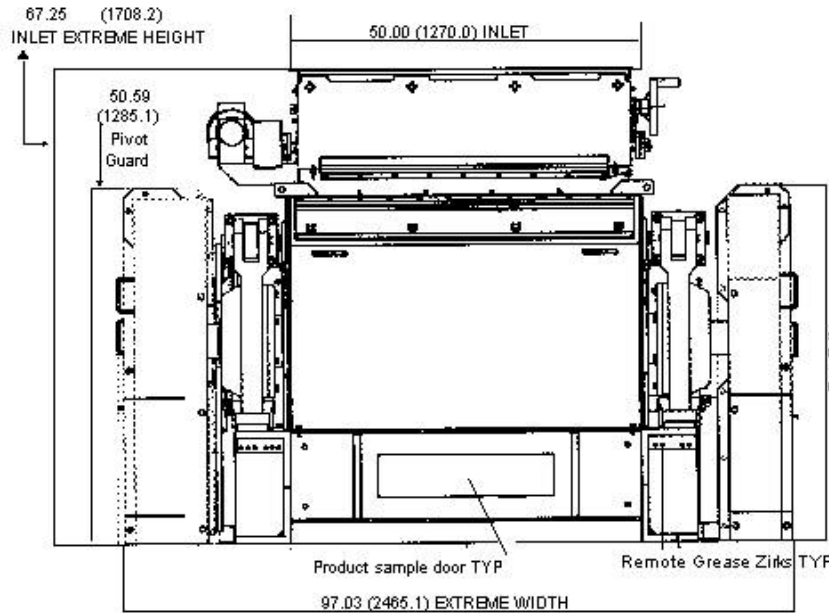

FRONT VIEW

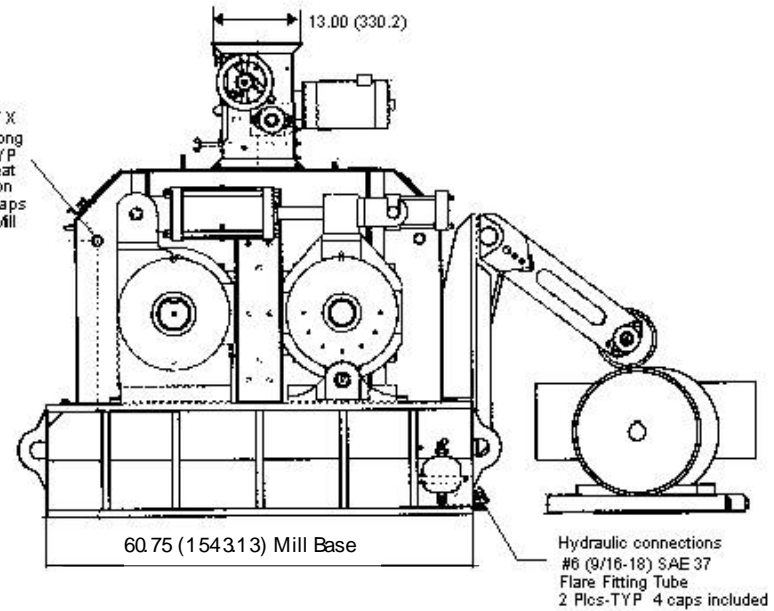

RIGHT SIDE VIEW, GUARDS REMOVED TO SHOW ROLL PREHEAT & HYDRAULIC FITTINGS

NOTES

1. Do not scale from drawing.
2. Alternative units (x.x) in millimeters.
3. Shipping weight 21,000 lb/9,526 KG.
4. Recommended maintenance clearance from mill base 48.00" (1219) at front and sides 12.00" (305) at rear.
5. Fixed & Pivot roll assemblies may be pulled from the front or rear of the housing.
6. Hydraulic connections #6 (9/16-18) SAE 37 (JIC) flare fitting tube. Maximum recommended hydraulic pressure: 1800 psi/126.55 KSC.
7. Roll preheat steam operating pressure: 15 PSI (1.05 kg/sq cm) maximum recommended steam pressure 50psi (3.52 kg/sq cm)
8. Two #6 x 120" (3048) long hydraulic hoses included with mill to connect pump to mill.
9. Mill Base ASTM A36 8x1" angle and MC13 x 50 painted finish. Mill housing ASTM A240, A276, T304 SS, # 3 polished external finish.



1440 SOUTH ADAMS STREET, BLUFFTON, IN 46714 USA (260) 824-3400 (800) 248-8318 FAX (260) 824-5463
www.ferrell-ross.com info@atferrell.com