

The Ferrell-Ross Model "M" Roller Mill

For Medium-Duty Particle Reduction



Ferrell-Ross is known worldwide for its heavy-duty industrial roller mills. The Model "M" was developed as a scaled-down version of our industrial mill especially for customers with easy-to-grind products and low tonnage requirements.

Model "M" applications include plastics, spices, nuts, food products, desiccants, various dry chemicals and feed processing.

The Model "M" mill utilizes 10" chilled cast rolls of the same quality as our industrial machines. These provide more surface area at the roll nip and a more controlled particle size.

We will test your product free of charge! Send us a small quantity of your product for lab testing and we will recommend the model and accessories needed to obtain the sizing and capacity you require.

The Model "M" is available as either a single-high with one pair of rolls, or a double reduction two-high with one pair of rolls mounted on top of the other. Either mill is available with a variety of roll corrugations and can be ordered with or without an inlet hopper.

For more information, call our product specialist toll free at 1-800/248-8318.

Ferrell-Ross
MATERIALS PROCESSING & RECOVERY

1440 SOUTH ADAMS STREET, BLUFFTON, IN 46714 USA (260) 824-3400 (800) 248-8318 FAX (260) 824-5463
www.atferrell.com info@atferrell.com

THE FERRELL-ROSS MODEL "M" MILL CAPACITIES

Roll Size	Motor H.P. Required		Corrug per in. *	Hi-Moisture (70#/Bu)		Dry Corn (56#/Bu)		Milo (56#/Bu)		Wheat (60#/Bu)		Oats (37#/Bu)		Barley (50#/Bu)									
	Single	2-Hi		Bu/Hr	Kg/Min	Bu/Hr	Kg/Min	Bu/Hr	Kg/Min	Bu/Hr	Kg/Min	Bu/Hr	Kg/Min	Bu/Hr	Kg/Min								
10 x 6	3	7.5	5	180	95	200	84	80	34	50	21	60	25	50	21								
			10			80	34									80	34	50	21	60	25	50	21
			13			50	21									53	22	36	15	42	18	36	15
10 x 12	5	10	5	365	193	400	168	160	67	95	40	100	42	95	40								
			10			160	67									160	67	95	40	100	42	95	40
			13			100	42									130	55	70	30	60	25	70	30
10 x 18	7.5	15	5	545	288	600	252	240	100	130	55	140	60	130	55								
			10			240	100									240	100	130	55	140	60	130	55
			13			150	63									200	84	65	27	85	36	65	27
10 x 24	10	20	5	730	386	800	336	320	134	175	74	190	80	175	74								
			10			320	134									320	134	175	74	190	80	175	74
			13			200	84									260	110	90	38	115	48	90	38
10 x 30	15	25	5	910	481	1000	420	400	168	215	90	225	95	215	90								
			10			400	168									400	168	215	90	225	95	215	90
			13			250	105									320	134	110	46	135	57	110	46
10 x 36	20	30	5	1100	582	1200	504	480	202	235	100	250	105	235	100								
			10			480	202									480	202	235	100	250	105	235	100
			13			300	126									390	164	120	51	150	63	120	51

All projected capacities listed are only estimates. The capacity of any roller or flaking mill will vary depending on quality of the grain, roll spacing (gap), horse power, differential roll speed and the general operation of the mill.

* 5 groove per inch corrugations are normally used for coarse cracking of corn.

10 groove per inch corrugations are normally used for processing a combination of grains on a single pair roller mill.

13 groove per inch corrugations are normally used for processing small grains on a single pair mill and/or double reduction on a 2-Hi mill.

Dimensions (inches)

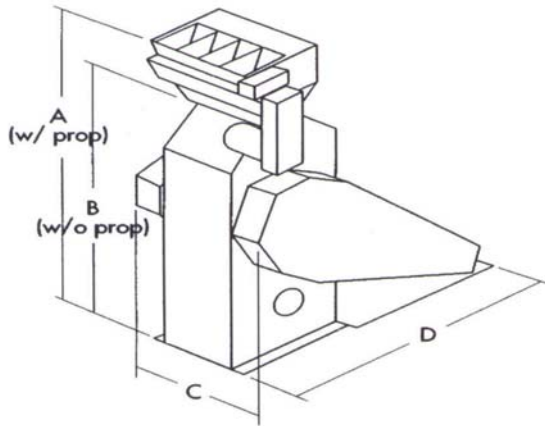

		A	B	C
1-Hi Mill	10 x 6	42	28.5	54.25
	10 x 12	42	34.5	54.25
	10 x 18	42	40.5	54.25
	10 x 24	42	46.5	54.25
	10 x 30	42	52.5	54.25
	10 x 36	42	58.5	54.25
2-Hi-Mill	10 x 12	60.25	35.5	54 7/8
	10 x 18	60.25	41.5	54 7/8
	10 x 24	60.25	47.5	56 7/8
	10 x 30	60.25	53.5	56 7/8
	10 x 36	60.25	59.5	56 7/8

Ferrell-Ross

MATERIALS PROCESSING & RECOVERY

1440 SOUTH ADAMS STREET, BLUFFTON, IN 46714 USA (260)824 3400 (800) 248 8318 FAX (260) 824 5463
www.atferrell.com info@atferrell.com